

TU SERIES SPECIFICATIONS



Simply...

The Most Advanced Wrench Ever Produced

- Faster Stroke!
- Anti-Back Lash Mechanism!
- Hands-Off Operation!
- Accurate Repeatability!
- Less Moving Parts!
- Patented Mono-Body Housing!
- Unique Design to Fit Every Application!

Are only a few of the Improvements that **torcUP** has brought to the Industry!

Technical

Model No.	TU-2	TU-3	TU-7	TU-11	TU-27	TU-60
Square Drive	3/4"	1"	1.1/2"	1.1/2"	2.1/2"	2.1/2"
Min. Torque Kg-m(Ft/Lbs)	17(127)	45(330)	102(740)	152(1,100)	376(2,720)	801(5,800)
Max. Torque Kg-m(Ft/Lbs)	175(1,270)	460(3,330)	1020(7,400)	1520(11,010)	3760(27,200)	8018(58,000)
Output Accuracy	+/-3%	+/-3%	+/-3%	+/-3%	+/-3%	+/-3%
Repeatability	100%	100%	100%	100%	100%	100%
Duty Cycle	100%	100%	100%	100%	100%	100%
Tool Weight Kgs/(Lbs)	1.77/(3.90)	4.09/(9.00)	8.64/(19.00)	13.18/(29.00)	31.81/(70.00)	59.00/(130.00)

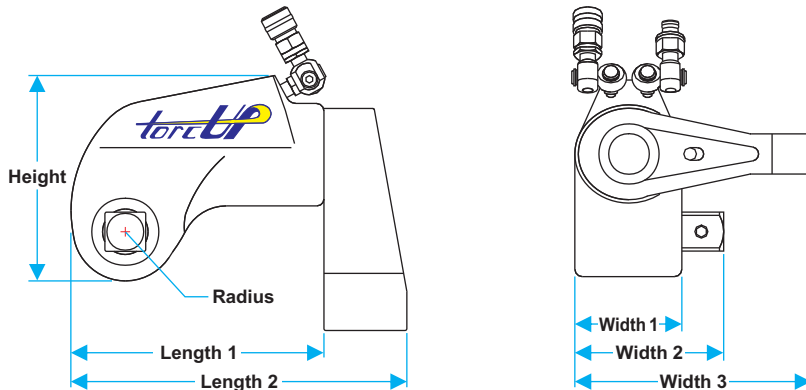

Dimensions

Model No.	TU-2		TU-3		TU-7		TU-11		TU-27		TU-60	
	mm	inch	mm	inch	mm	inch	mm	inch	mm	inch	mm	inch
Height	106.68	4.20	134.62	5.30	177.55	6.99	197.87	7.79	258.83	10.19	292.10	11.50
Length 1	118.87	4.68	154.94	6.10	203.20	8.00	233.93	9.21	312.17	12.29	390.65	15.38
Length 2	157.48	6.20	205.74	8.10	272.80	10.74	310.13	12.21	413.77	16.29	518.16	20.40
Radius	24.89	0.98	33.02	1.30	43.18	1.70	49.53	1.95	61.72	2.43	73.66	2.90
Width 1	50.80	2.00	66.54	2.62	91.69	3.61	99.82	3.93	133.60	5.26	167.13	6.58
Width 2	70.87	2.79	93.47	3.68	128.52	5.06	137.92	5.43	196.34	7.73	225.80	8.89
Width 3	112.27	4.42	147.57	5.81	202.69	7.98	221.49	8.72	295.40	11.63	368.00	14.49

Note : • All tool weights include Couplers, Swivels, Reaction Arm and Internal Oil.
 • The Patented Mono-Body Housing is standard on all models.

TU Accessories

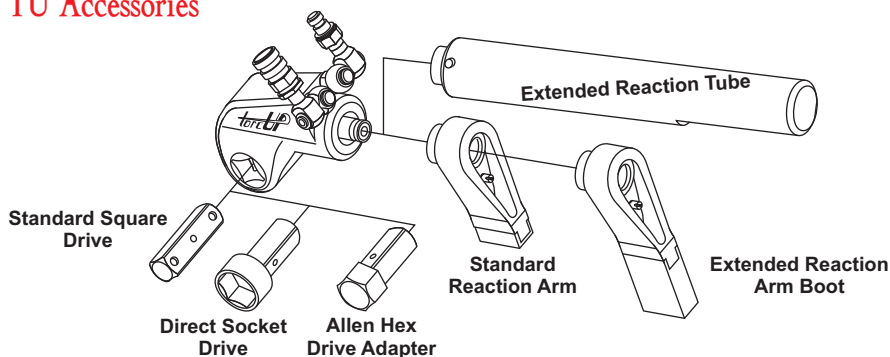

POWERMASTER
 has in stock application
 specific accessories to fit on your job!

Call
POWERMASTER
 today for help
 with your application specification!

TU SERIES FEATURES

TU Square Drive - The Performer



▲
TU-2 Achieves Proper Torque in Seconds !

TU-10 The Workhorse in Power Generation ▶



The **torcUP** Multi-Application TU Series is the tool of choice on every application in every industry. Whether in a steel mill, on an offshore drill platform or diving to the ocean bottom a **torcUP** TU Wrench will **OUTPERFORM** every other method of tightening threaded fasteners.

**Tensioners...Impact Wrenches...
Nut Runners...
are no match for
A TU Hydraulic Wrench on
any application !!**

**Other Hydraulic Wrench manufacturers?
Not a chance!!**

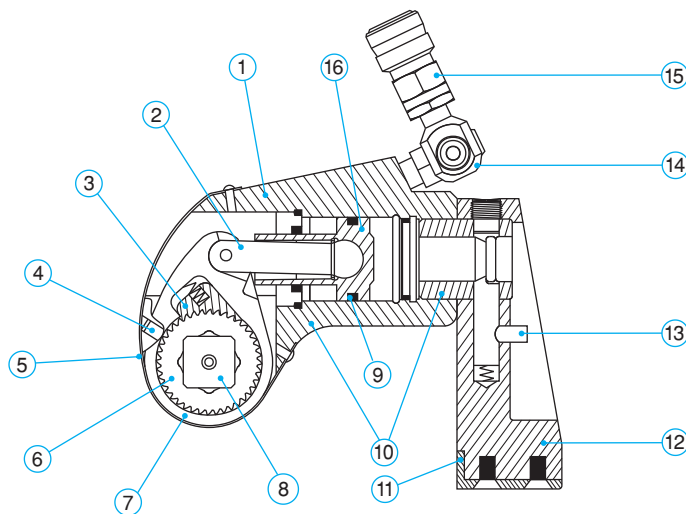

1	Patented Mono-Body Housing	A TorcUP exclusive!!
2	Balanced Drive Rod	Side load free piston movement.
3	Never-Lock Drive Pawl	Ensures tool will NEVER lock up.
4	Anti-Back Lash Mechanism	Provides hands free operation.
5	Laser Engraved Torque Chart	No more searching for charts.
6	Multi-Tooth Ratchet	Allows for 27 degree torque stroke accuracy.
7	One Piece Drive Plate	Robust alloy provides for small nose radius.
8	Push-Through-Drive	Simply push to switch from loosen to tighten.
9	Single Seal Piston	Assures extended maintenance free operation.
10	Direct Housing Reaction	Allows use of tool without reaction arm.
11	Steel Reaction Boot	Field replaceable feature protects reaction arm.
12	Long Length Reaction Arm	Allows for reaction on all applications.
13	Reaction Arm Release Button	Protected within reaction arm housing.
14	360 x 360 Swivel	Allows hose to be cleared on all applications.
15	No-Drip Quick Connect Couplers	Assures easy and safe operation.
16	Steel Alloy Piston	Robust composition allows for longer operation cycle.

TX SERIES SPECIFICATIONS



Simply...

The Flattest Hydraulic Wrench Ever Produced

- Flat Design from Cylinder to Link!
- Unique Peanut Shaped Piston!
- Direct Flow Oil Distribution for Faster Stroke!
- Less Moving Parts!
- Accurate Repeatability!
- Hands-Off Operation!

Are only a few of the reasons why the **torqueUP** TX is the only tool of its kind!

Technical

Model No.	TX-2	TX-4	TX-8	TX-16	TX-32
Tool Hex from	19mm / 3/4"	25mm / 1"	50mm / 1.7/8"	65mm / 2.5/8"	80mm / 3.1/8"
to	60mm / 2.3/8"	80mm / 3.1/8"	105mm / 4"	115mm / 4.5/8"	155mm / 6.1/8"
Min. Torque Kg-m (Ft/Lbs)	26 (192)	54 (395)	115 (830)	215 (1,560)	445 (3,220)
Max. Torque Kg-m (Ft/Lbs)	260 (1,928)	540 (3,950)	1192 (8,630)	2293 (16,600)	4924 (35,650)
Output Accuracy	+/- 3%	+/- 3%	+/- 3%	+/- 3%	+/- 3%
Repeatability	100%	100%	100%	100%	100%
Duty Cycle	100%	100%	100%	100%	100%
Corrosion Protection	Standard				
Cylinder Weight Kgs / (Lbs)	1.59 / (3.50)	2.73 / (6.00)	5.32 / (11.70)	7.27 / (16.00)	11.82 / (26.00)
Link Weight from Kgs / (Lbs)	1.09 / (2.40)	2.45 / (5.40)	5.41 / (11.90)	9.55 / (21.00)	13.18 / (29.00)
to Kgs / (Lbs)	1.59 / (3.50)	3.45 / (7.60)	6.59 / (14.50)	12.73 / (28.00)	17.95 / (39.50)

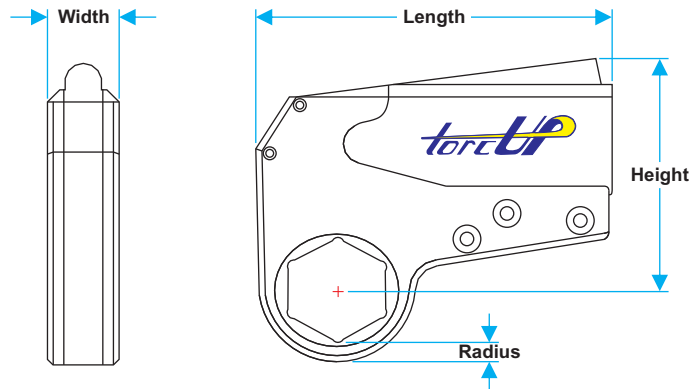

Dimensions

Model No.	TX-2		TX-4		TX-8		TX-16		TX-32	
	mm	inch	mm	inch	mm	inch	mm	inch	mm	inch
Length	144.00	5.67	198.12	7.80	248.92	9.80	328.42	12.93	388.62	15.30
Height	101.60	4.00	142.24	5.60	177.80	7.00	192.53	7.58	276.86	10.90
Width	31.75	1.25	41.40	1.63	52.07	2.05	63.50	2.50	82.30	3.24
Radius	9.14	0.36	11.68	0.46	13.72	0.54	16.51	0.65	23.62	0.93

- Note :**
- All tool weights include Couplers, Swivels and Internal Oil.
 - The Patented Peanut Shaped Cylinder Bore is standard on TX-2, TX-4 and TX-8 models.

TU Accessories

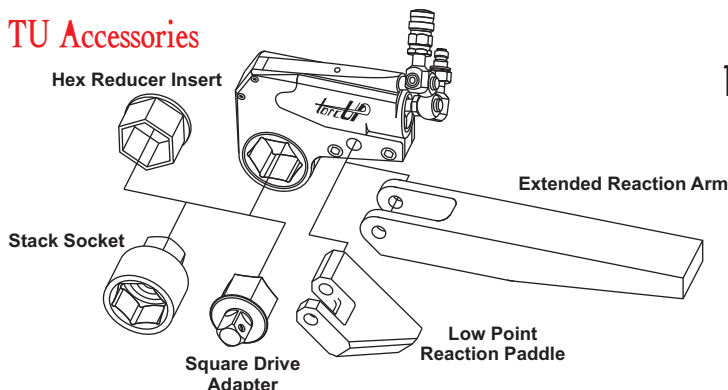

When clearance is an issue... TX is the answer!
TX accessories allow you to convert your low profile system into a multi-application system simply by inserting hex accessories.

Call
POWERMASTER
to solve any of your limited area,
low clearance bolting applications.

TX SERIES FEATURES

TX Low Profile - The Solution



TX saves time when precise torque is required

- Clearance **ABOVE** The Nut - No Problem For A TX!
- Clearance **BEHIND** The Nut - No Problem For A TX!
- Clearance **BETWEEN** The Nut - No Problem For A TX!

The **torcUP** Patented Peanut Shape Piston Design assures That your application will have the correct torque applied every time.

- Tensioners - Too Big To Fit!
- Multipliers - Too Big To Fit!
- Nut Runners - Too Big To Fit!
- Impact Wrenches - Too Big To Fit!
- Other Hydraulic Wrenches - Too Big To Fit!

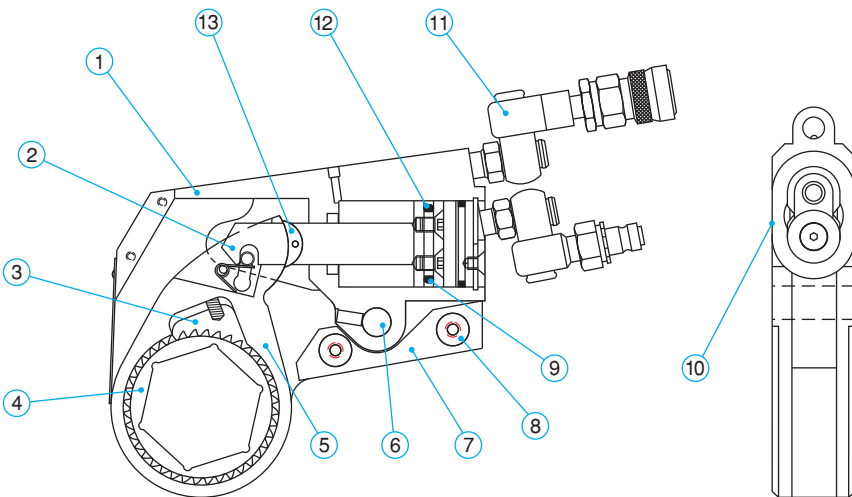

TX cylinder and link are the same width. A TorcUP exclusive.

1	Patented "Peanut Shaped Cylinder"	Fit both the cylinder and link in confined areas.
2	Engagement Rod	Automatically engages link on the first stroke.
3	Never-Lock Drive Pawl	Ensures tool will NEVER lock up.
4	Multi-Tooth Ratchet	Allows for 27 degree torque stroke accuracy.
5	One Piece Drive Plate	Robust alloy provides for small nose radius.
6	Link Pin	One pin for link to cylinder engagement. No tools required.
7	In-Line Reaction Pad	Assures torsion free reaction every time.
8	Steel Alignment Pin	Assures equal load displacement between side plates.
9	Piston Tension O-Ring	Tension locks piston seal into "Peanut" bore.
10	Completely Flat Design	Cylinder and link width are equal for tight fits.
11	360 x 360 Swivel	Allows hose to be cleared on all applications.
12	Teflon Piston Seal	Patented technology provides years of maintenance free use.
13	Slider	Prevents wear of piston or drive plate. Reduces costly repairs.

TX SERIES HEX LINK PART NUMBERS

TX-2 Link	Hex	TX-4 Link	Hex	TX-8 Link	Hex	TX-16 Link	Hex	TX-32 Link	Hex
Number	Size	Number	Size	Number	Size	Number	Size	Number	Size
TX-2RL012	3/4"	TX-4RL100	1"	TX-8RL114	1.7/8"	TX-16RL210	2.5/8"	TX-32RL302	3.1/8"
TX-2RL013	13/16"	TX-4RL101	1.1/16"	TX-8RL115	1.15/16"	TX-16RL211	2.11/16"	TX-32RL303	3.3/16"
TX-2RL014	7/8"	TX-4RL102	1.1/8"	TX-8RL200	2"	TX-16RL212	2.3/4"	TX-32RL304	3.1/4"
TX-2RL015	15/16"	TX-4RL103	1.3/16"	TX-8RL201	2.1/16"	TX-16RL213	2.13/16"	TX-32RL305	3.5/16"
TX-2RL100	1"	TX-4RL104	1.1/4"	TX-8RL202	2.1/8"	TX-16RL214	2.7/8"	TX-32RL306	3.3/8"
TX-2RL101	1.1/16"	TX-4RL105	1.5/16"	TX-8RL203	2.3/16"	TX-16RL215	2.15/16"	TX-32RL307	3.7/16"
TX-2RL102	1.1/8"	TX-4RL106	1.3/8"	TX-8RL204	2.1/4"	TX-16RL300	3"	TX-32RL308	3.1/2"
TX-2RL103	1.3/16"	TX-4RL107	1.7/16"	TX-8RL205	2.5/16"	TX-16RL301	3.1/16"	TX-32RL309	3.9/16"
TX-2RL104	1.1/4"	TX-4RL108	1.1/2"	TX-8RL206	2.3/8"	TX-16RL302	3.1/8"	TX-32RL310	3.5/8"
TX-2RL105	1.5/16"	TX-4RL109	1.9/16"	TX-8RL207	2.7/16"	TX-16RL303	3.3/16"	TX-32RL311	3.11/16"
TX-2RL106	1.3/8"	TX-4RL110	1.5/8"	TX-8RL208	2.1/2"	TX-16RL304	3.1/4"	TX-32RL312	3.3/4"
TX-2RL107	1.7/16"	TX-4RL111	1.11/16"	TX-8RL209	2.9/16"	TX-16RL305	3.5/16"	TX-32RL313	3.13/16"
TX-2RL108	1.1/2"	TX-4RL112	1.3/4"	TX-8RL210	2.5/8"	TX-16RL306	3.3/8"	TX-32RL314	3.7/8"
TX-2RL109	1.9/16"	TX-4RL113	1.13/16"	TX-8RL211	2.11/16"	TX-16RL307	3.7/16"	TX-32RL315	3.15/16"
TX-2RL110	1.5/8"	TX-4RL114	1.7/8"	TX-8RL212	2.3/4"	TX-16RL308	3.1/2"	TX-32RL400	4"
TX-2RL111	1.11/16"	TX-4RL115	1.15/16"	TX-8RL213	2.13/16"	TX-16RL309	3.9/16"	TX-32RL401	4.1/16"
TX-2RL112	1.3/4"	TX-4RL200	2"	TX-8RL214	2.7/8"	TX-16RL310	3.5/8"	TX-32RL402	4.1/8"
TX-2RL113	1.13/16"	TX-4RL201	2.1/16"	TX-8RL215	2.15/16"	TX-16RL311	3.11/16"	TX-32RL403	4.3/16"
TX-2RL114	1.7/8"	TX-4RL202	2.1/8"	TX-8RL300	3"	TX-16RL312	3.3/4"	TX-32RL404	4.1/4"
TX-2RL115	1.15/16"	TX-4RL203	2.3/16"	TX-8RL301	3.1/16"	TX-16RL313	3.13/16"	TX-32RL405	4.5/16"
TX-2RL200	2"	TX-4RL204	2.1/4"	TX-8RL302	3.1/8"	TX-16RL314	3.7/8"	TX-32RL406	4.3/8"
TX-2RL201	2.1/16"	TX-4RL205	2.5/16"	TX-8RL303	3.3/16"	TX-16RL315	3.15/16"	TX-32RL407	4.7/16"
TX-2RL202	2.1/8"	TX-4RL206	2.3/8"	TX-8RL304	3.1/4"	TX-16RL400	4"	TX-32RL408	4.1/2"
TX-2RL203	2.3/16"	TX-4RL207	2.7/16"	TX-8RL305	3.5/16"	TX-16RL401	4.1/16"	TX-32RL409	4.9/16"
TX-2RL204	2.1/4"	TX-4RL208	2.1/2"	TX-8RL306	3.3/8"	TX-16RL402	4.1/8"	TX-32RL410	4.5/8"
TX-2RL205	2.5/16"	TX-4RL209	2.9/16"	TX-8RL307	3.7/16"	TX-16RL403	4.3/16"	TX-32RL411	4.11/16"
TX-2RL206	2.3/8"	TX-4RL210	2.5/8"	TX-8RL308	3.1/2"	TX-16RL404	4.1/4"	TX-32RL412	4.3/4"
		TX-4RL211	2.11/16"	TX-8RL309	3.9/16"	TX-16RL405	4.5/16"	TX-32RL413	4.13/16"
		TX-4RL212	2.3/4"	TX-8RL310	3.5/8"	TX-16RL406	4.3/8"	TX-32RL414	4.7/8"
		TX-4RL213	2.13/16"	TX-8RL311	3.11/16"	TX-16RL407	4.7/16"	TX-32RL415	4.15/16"
		TX-4RL214	2.7/8"	TX-8RL312	3.3/4"	TX-16RL408	4.1/2"	TX-32RL500	5"
		TX-4RL215	2.15/16"	TX-8RL313	3.13/16"	TX-16RL409	4.9/16"	TX-32RL501	5.1/16"
		TX-4RL300	3"	TX-8RL314	3.7/8"	TX-16RL410	4.5/8"	TX-32RL502	5.1/8"
		TX-4RL301	3.1/16"	TX-8RL315	3.15/16"			TX-32RL503	5.3/16"
		TX-4RL302	3.1/8"	TX-8RL400	4"			TX-32RL504	5.1/4"
								TX-32RL505	5.5/16"
								TX-32RL506	5.3/8"
								TX-32RL507	5.7/16"
								TX-32RL508	5.1/2"
								TX-32RL509	5.9/16"
								TX-32RL510	5.5/8"
								TX-32RL511	5.11/16"
								TX-32RL512	5.3/4"
								TX-32RL513	5.13/16"
								TX-32RL514	5.7/8"
								TX-32RL515	5.15/16"
								TX-32RL600	6"
								TX-32RL601	6.1/16"
								TX-32RL602	6.1/8"

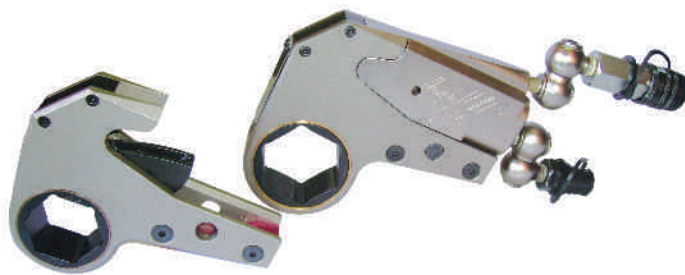

▲
Change sizes by removing single link pin

All TX series links are available in MM sizes also. Consult POWERMASTER for part numbers.

QUADRA-TORC SYSTEM

Quadra-Torc - Fast-Accurate-Even Bolt Load

The primary focus of the Quadra-Torc System is to eliminate the common "Criss-Cross" bolt tightening pattern that causes constant crush or over torque of gaskets. With the Quadra-Torc System multi **torcUP** torque units are utilized along with our Quadra-Torc Hydraulic Pumps. Once the **torcUP** wrenches are in place a single operator can apply even load at the push of a button. The Quadra-Torc System will evenly close the gap and apply equal torque to $\pm 3\%$ accuracy!



Get Into Speed Torque Mode With Quadra-Torc!

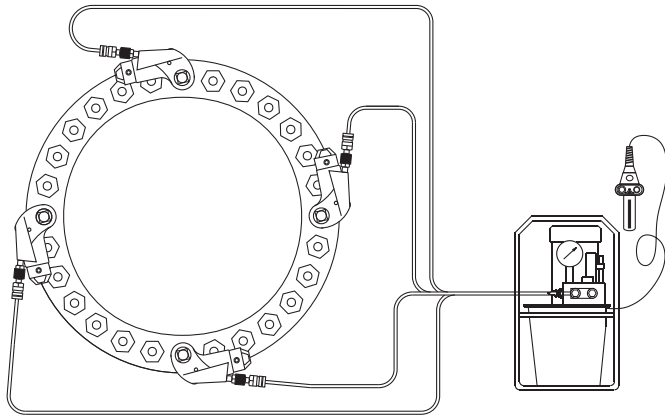

Quadra-Torc four tool system

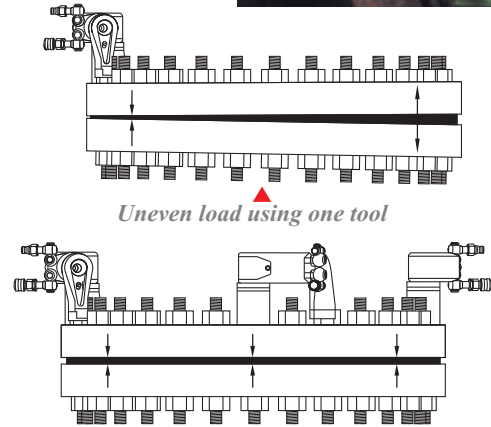

Uneven load using one tool

Even and precise load with Quadra-Torc

BOLTING SERVICES

Powermaster - Offers A Complete Hydraulic Bolting Service.....

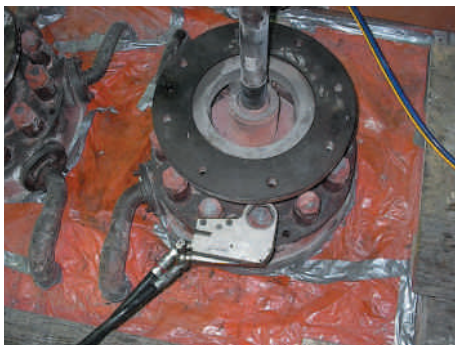

Powermaster Bolting Services offer the following advantages :

- **Safe :** Powermaster supervisors ensure a trouble free job. Powermaster bolting technicians have undergone training from M/S TorcUP (USA) and our services meet MMS, USCG and DSHA regulations.
- **Fast :** Skilled and experienced crew will allow the job to be completed faster and better than a 'First Time' crew.
- **Economical :** Since most companies use hydraulic bolting tools for a small part of the year, in a lot of cases it does not justify the large investment needed to purchase the tools.
- **Time Savings :** Since Powermaster carries a fleet of hydraulic bolting tools in its ISO-9002 certified facility, our crew can be on site and on the job in matter of days, versus the weeks and sometimes months it takes for a company to import and commission a new set of hydraulic bolting tools.

RENTAL PROGRAMS

For customers who do not have the need for Powermaster crew, they have the option of renting Powermaster tools at a nominal cost. Powermaster recommends an orientation of the use of its tools at its factory in Thane, Maharashtra, before the tools are sent out to the customer on rent. Please contact us for rental information and prices.

POWER PACKS

Quadra-Torc - (4 Port)

Electric



◀ **EP1000**
(Shown with Mono-Port)

EP1000 - High Flow - High Speed for Heavy Duty Application

- Quadra-Torc Multi-Port Manifold (Max. 4 Ports).
- Cool running continuous duty axial piston pump.
- Single phase induction motor.
- 115V and 230V available.
- Starts under full load.
- Runs on reduced voltage.
- Quiet operation (approx. 80 dBA @ 10,000 PSI).
- Rugged remote pendant to control motor and valve.
- Easily adjustable pressure control knob.
- Auto-dump relieves oil pressure from hoses.
- Completely enclosed motor housing and electronics.
- 2 Gallon oil reservoir.
- Precise PSI/BAR pressure gauge.
- Quick-connect no-drip couplers with safety locking collar.
- Supplied with dual non-conductive high pressure hose with couplers.

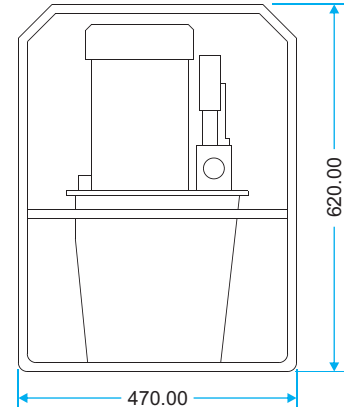
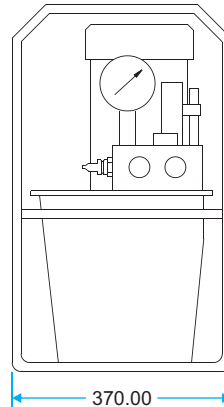

Resvr. Size (Gal.)	Valve		Motor Specifications	Flow Rate @ 115 VAC		Weight	
	Control	Type		600 psi	10,000 psi	kg	lbs
2	Solenoid	3 Way/2 Pos.	1.5 HP Single Phase	11.47 lpm	0.82 lpm	38	84

Retract pressure is preset at 1,300 PSI.

Pneumatic



◀ **AP1000**
(Shown with Mono-Port)

AP1000 - High Flow - High Speed for Heavy Duty Application

- Quadra-Torc Multi-Port Manifold (Max. 4 Ports).
- Cool running continuous duty axial piston pump.
- Powerful 1.5HP industrial duty air motor.
- Runs on 50 cfm / 80 PSI of air.
- Quiet operation (approx. 80 dBA @ 10,000 PSI).
- Rugged remote pendant to control motor and valve.
- Easily adjustable pressure control knob.
- Auto-dump relieves oil pressure from hoses.
- Filter-lubricator for long trouble free operation.
- 2 Gallon oil reservoir.
- Precise PSI/BAR pressure gauge.
- Quick-connect no-drip couplers with safety locking collar.
- Supplied with dual non-conductive high pressure hose with couplers.

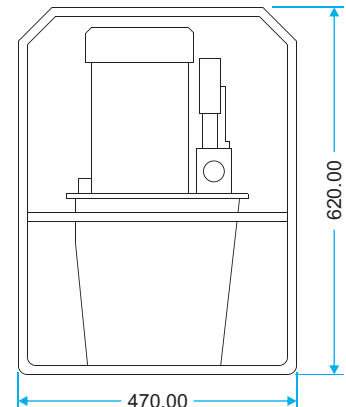
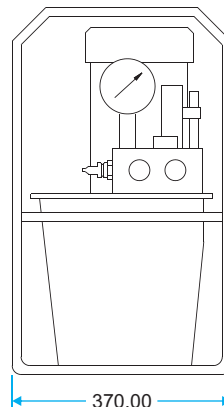

Resvr. Size (Gal.)	Valve		Motor Specifications	Flow Rate @ 50 cfm/ 90psi		Weight	
	Control	Type		600 psi	10,000 psi	kg	lbs
2	Solenoid	3 Way/2 Pos.	1.5 HP Rotary Air	9.83 lpm	0.82 lpm	27	59

Retract pressure is preset at 1,300 PSI.

Standard Roll Bar Dimensions : 25-7/16" L x 20-1/2" H x 166-3/4" W