

TUBE / PIPE BEVELLING MACHINES

FM-1625

The FM-1625 is light weight and powerful machine for facing, bevelling, and weld preparation. It is compact, easy to handle and quick to setup. It is used for jobs in restricted access areas. Used in shutdown environments on condensers and heat exchangers.

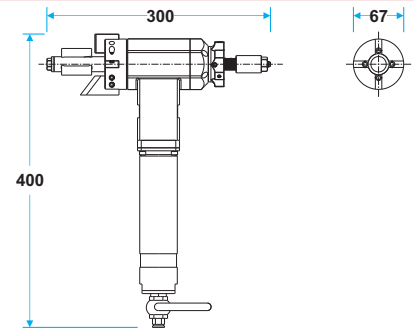

Drive	Pneumatic	Electric
Locking Range (mm)	20 - 42	20 - 42
Ideal Speed (RPM)	240	178
Torque (Nm)	27.5	45.0
Feeding Stroke (mm)	23	23
Pneumatic Power (HP)	0.60	--
Air Consumption (cfm)	16	--
Air Pressure (psi)	90	--
Electric Power (watts)	--	650
Weight (kg)	5.5	5.5

CUTTING BITS

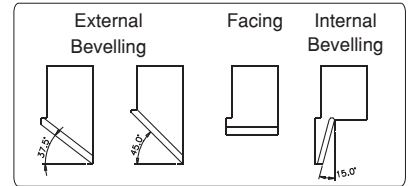

FM-3000

The FM-3000 the most popular and powerful machine. Used during maintenance and new boiler manufacturing. Quick interchangeability of locking jaws to suit wide range of dia meters. Modular and ergonomic design.

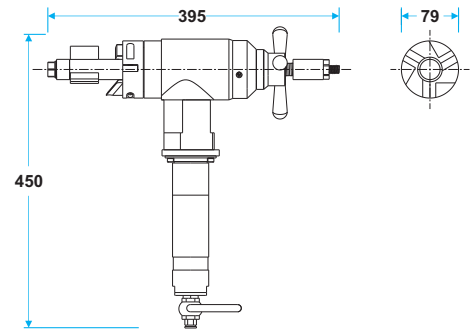

Drive	Pneumatic	Electric
Locking Range (mm)	28 - 76	28 - 76
Ideal Speed (RPM)	110	215
Torque (Nm)	84	138
Feeding Stroke (mm)	40	40
Pneumatic Power (HP)	0.83	--
Air Consumption (cfm)	42	--
Air Pressure (psi)	90	--
Electric Power (watts)	--	595
Weight (kg)	9.5	14.0

CUTTING BITS

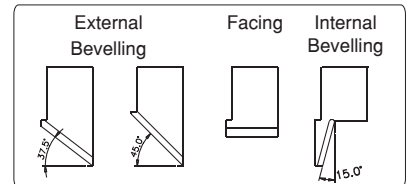

FM-4500

The FM-4500 is a heavy duty machine designed to bevel, face and prepare weld edges for heavy wall thickness tubes. Modular and ergonomic design.

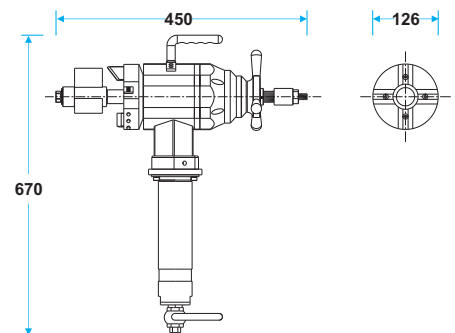

Drive	Pneumatic	Electric
Locking Range (mm)	39 - 104	39 - 104
Ideal Speed (RPM)	35	115
Torque (Nm)	220	240
Feeding Stroke (mm)	40	40
Pneumatic Power (HP)	1.3	--
Air Consumption (cfm)	40	--
Air Pressure (psi)	90	--
Electric Power (watts)	--	1800
Weight (kg)	21.0	23.0

CUTTING BITS

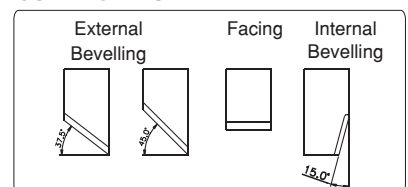

TUBE / PIPE BEVELLING MACHINES

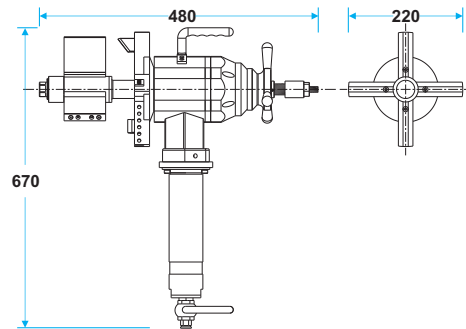
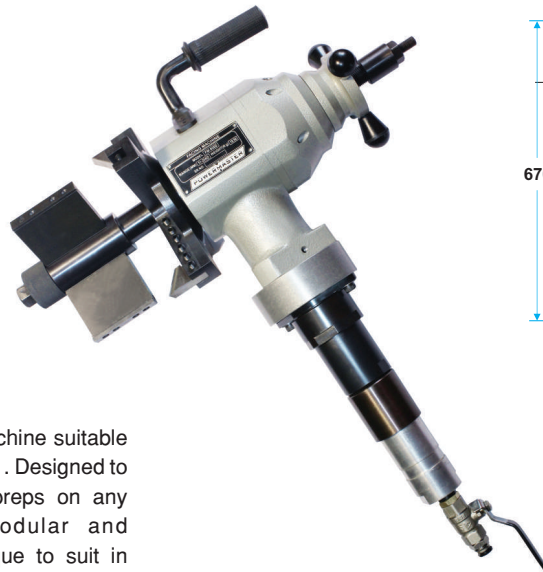

FM-8000

The FM-8000 is a heavy duty machine suitable for use on a wide range of tube Id's. Designed to bevel, face and produce weld preps on any thickness pipe or tube. Modular and ergonomic design with high torque to suit in toughest working condition.

Drive	Pneumatic	Electric
Locking Range (mm)	51 - 203	51 - 203
Ideal Speed (RPM)	35	30
Torque (NM)	220	240
Feeding Stroke (mm)	40	40
Pneumatic Power (HP)	1.3	--
Air Consumption (cfm)	40	--
Air Pressure (psi)	90	--
Electric Power (watts)	--	1800
Weight (Kg)	26.5	30.0

CUTTING BITS

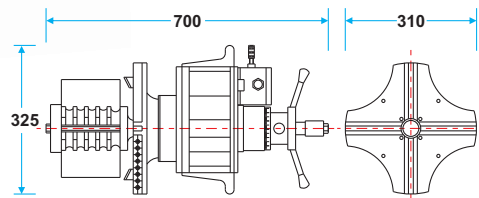
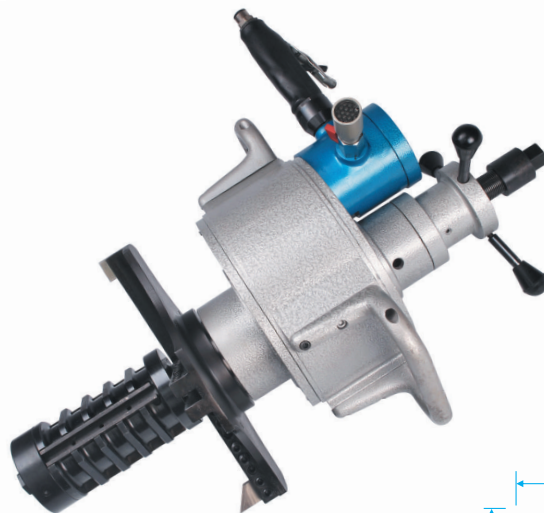
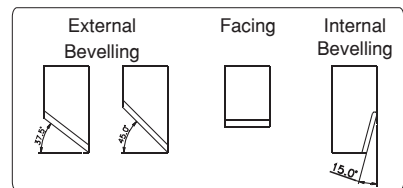

FM-12000

The FM-12000 is a combination of power and range in a light and portable design. Wide range for tube end facing, beveling, counter boring and weld edge preparation. Rugged and balanced machine suitable for all sizes of tube and pipes.

Drive	Pneumatic	Electric
Locking Range (mm)	100 - 306	100 - 306
Ideal Speed (RPM)	35	31
Torque (Nm)	180	230
Feeding Stroke (mm)	50	50
Pneumatic Power (HP)	1.9	--
Air Consumption (cfm)	60	--
Air Pressure (psi)	90	--
Electric Power (watts)	--	1400
Weight (kg)	43.0	44.0

CUTTING BITS

