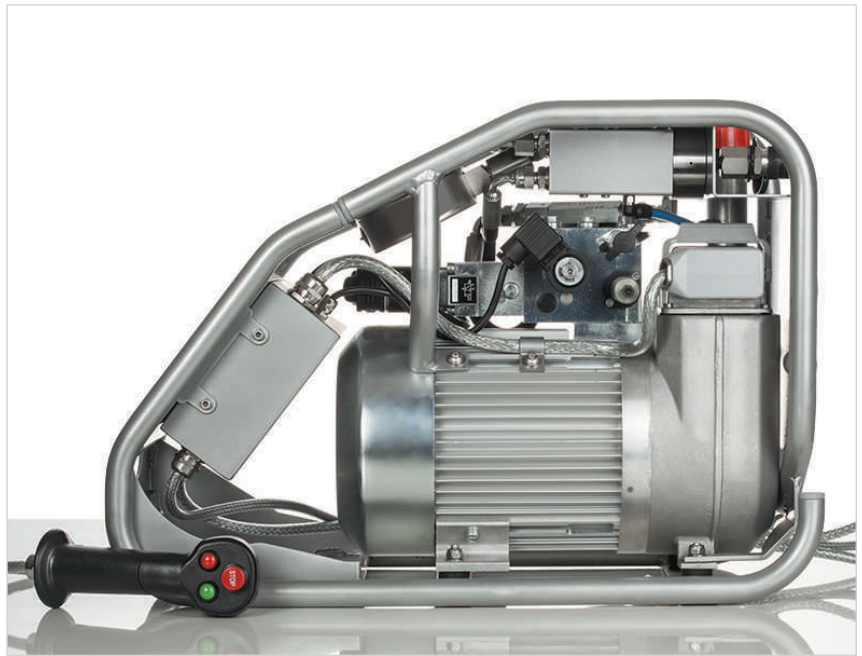

## ELECTRIC DRIVEN HYDRAULIC PUMP

*Applications :*

Electric driven hydraulic pump, usable worldwide up to 1600 bar for bolt tensioning tools.

- Totally remote control the pump from the controller hand grip.
- Designed to work in adverse environmental conditions.

*Features :*

- Huge oil flow due to intelligent electronic controlling and powerful motor.
- All from the remote hand control grip with one single operation..
- Extremely high quality valves and components for a high duty cycle to ensure reliability and durability of the unit.
- Low pressure return Filter and High Pressure Filter (10  $\mu$ m) with electronic clogging sensors and alarms in control box.
- Capable of continuous operation – minimal heat generation for efficient bolting.
- Low running costs - Brush-free synchronized motor, maintenance-free and low in wear.

# ELECTRIC DRIVEN HYDRAULIC PUMP

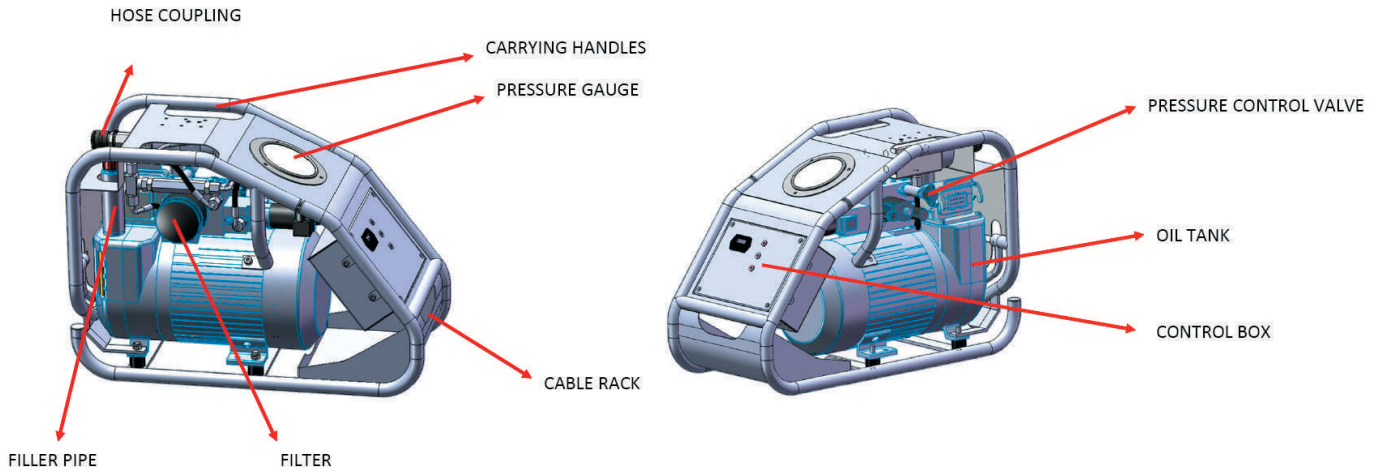

## Remote Control



## Technical Details:

Pump		
Current Supply		230V-50Hz / 100V-60Hz
Power	kW	1.5
Rated Current		10.5 A (230 V) / 20.5 A (110 V)
Starting Power		3.3 X IN
COS	Ø	0.94
Turning Speed	rpm	2800 r.p.m.
Tank Capacity	l	4.7 l.
Available Volume	l	1.7 l.
Oil Flow:		
Maximum Pressure	bar	2000
Weight		
Empty Weight	Kg	35
Dimensions		
L x W x H	mm	570 x 280 x 400