

BOLT TENSIONERS

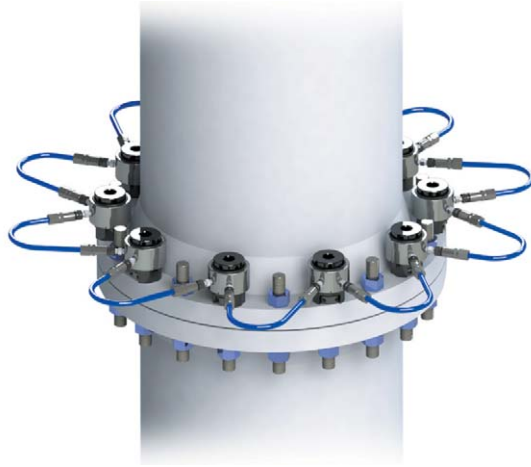

Bolt tensioning is now the preferred method of tightening bolts and studs on all critical applications. Bolt tensioners are designed for operation in a wide variety of applications including pipeline flanges, heat exchangers, pressure vessels, compressor covers, boiler feed pumps, windmills and many others. We provide a comprehensive range of bolt tensioners for optimum solutions to bolt tensioning requirements. Our Bolt tensioners and accessories are CE marked in accordance with Pressure Equipment and Machinery Directives, as applicable. In comparison to traditional tightening methods, tightening with bolt tensioners offers significant advantages:

- No torsional loading of fasteners.
- Direct loading - no damage to assembly.
- Easy and fast operation.
- Very high accuracy and repeatability.
- Automation feasible and can be used for critical applications.

PST SERIES TOPSIDE BOLT TENSIONERS



PST Series Bolt Tensioners are designed for operation in a wide variety of applications including pipeline flanges, heat exchangers, pressure vessels, compressor covers, boilers feed pumps, anchors bolts and many others.

The PST Bolt Tensioner is very simple to use and consists of four parts - Threaded Puller, Load Cell, Bridge and Nut Driver (Nut Rotating Socket).



THREADED PULLER



LOAD CELL



BRIDGE



NUT DRIVER /
NUT ROTATING SOCKET

PST SERIES TOPSIDE BOLT TENSIONERS

Brief Operational Sequence

The nut-driver is placed over the nut (**fig.1**). The bridge and load cell is then placed over the bolt (**fig.2**).

The Puller is then screwed over the stud protruding above the nut face (**fig.3**) making sure that at least 1 x diameter of bolt is engaged with the Threaded Puller.

Desired hydraulic pressure is now applied to load cell, which stretches the bolt. (**fig.4**). The nut is turned down using the nut-driver and tommy bar. The Pressure is then released leaving the stud loaded to the desired value.

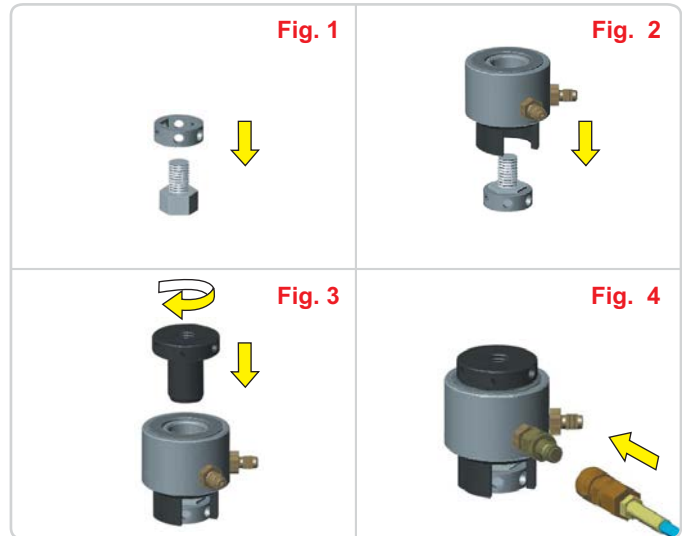

THE PST SERIES TOPSIDE BOLT TENSIONERS IS ONE OF THE MOST LIGHT, COMPACT AND VERSATILE LINE OF TENSIONERS AVAILABLE:

Features :

- Versatile Design:** The PST Series standard variable tensioners are designed to provide a wide range of flexibility, covering stud sizes from 3/4" to 5.3/4" (M-16 to M-150). Different stud sizes are accommodated by the same load cell by simply changing the adaptor kit consisting of Threaded Puller, Bridge and Nut Driver.
- High Strength Aircraft Quality Alloy Steel:** The PST Series tensioners operate at a maximum pressure of 1500 Bar and are manufactured from high strength AISI 4340 alloy steel parts for long lasting trouble free performance.
- Stroke Indicator:** The PST Series tensioners have and an exceptional stroke of 15 mm. The Integral Stroke Indicator allows the piston stroke to be viewed while tensioning is in progress. A Red line on piston indicates an over stroke ensuring safe operation.
- Safe Design in event of Piston 'Over Stroke':** The PST series tensioners are designed so that in event of over- stroke the high pressure fluid will be released from the inner side of the load cell, thus saving the operator from any potential exposure.
- Multi Tensioning:** The PST Series load cell is provisioned with two connections and this acts as a manifold for multi tensioning applications. By using high pressure link hoses, any number of bolt tensioners can be connected and used simultaneously. This ensures equal tightening of all bolts on the flange and reduces work time.
- Anti Roll, Composite Material Seals:** All PST Tensioners are fitted with Anti Roll, Composite Material seals for longer life and high reliability. The seals used have a low coefficient of friction so that the piston can be returned to a closed position with minimal effort. PST Series tensioners can be provided with machined PU (poly urethane) seals if requested by the customer.
- Floating Piston:** The unique piston design allows 2° tilt without any loss of load, preventing piston seizure or damage to piston bore.

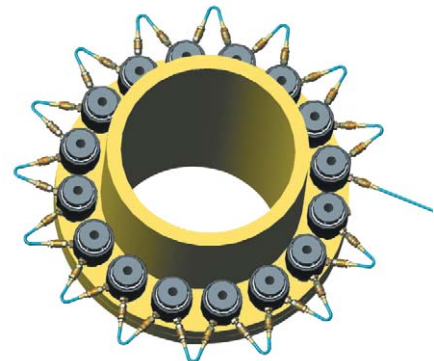

PST SERIES TOPSIDE BOLT TENSIONERS

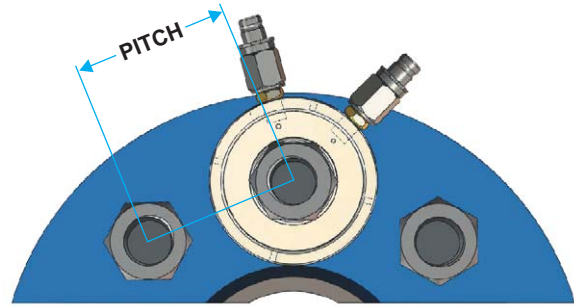
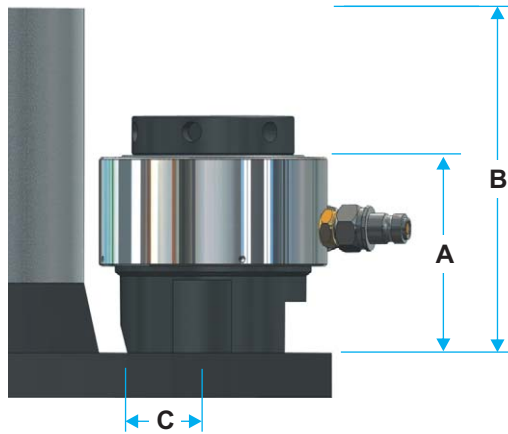

Technical Details:

Model No.		Bolt Size		Max Load		Hyd Area		O.D.	Min Pitch	Relief C	Height A	Clearance B	Weight
Load Cell	Adaptor Kit	inch	mm	M Ton	kN	in ²	mm ²	mm	mm	mm	mm	mm	kg.
PST-01	A1-0.12	3/4	20	34.5	339	3.50	2257	84	46	30	86	160	3.5*
	A1-M20		20						47	30	86	160	1.3
	A1-0.14	7/8	24						53	32	94	168	1.4
	A1-M24		24						54	32	94	168	1.4
	A1-1.00	1							55	32	94	168	1.4
PST-02	A2-M27		27	40.6	397	4.11	2649	98	56	34	96	170	4.5*
	A2-1.02	1.1/8	30						59	37	98	172	1.8
	A2-M30		30						62	37	97	173	1.9
	A2-1.04	1.1/4	33						67	40	99	180	2.0
	A2-M33		33						68	40	99	181	2.1
	A2-1.06	1.3/8	36						72	43	101	186	2.3
PST-03	A3-1.04	1.1/4	33	65.2	639	6.60	4259	115	73	43	101	187	2.3
	A3-M33		33						69	40	99	185	5.9*
	A3-1.06	1.3/8	36						70	40	99	174	2.4
	A3-M36		36						74	43	101	177	2.9
	A3-1.08	1.1/2	39						75	43	101	178	2.9
	A3-M39		39						80	45	105	187	3.0
PST-04	A4-1.06	1.3/8	36	73.6	721	7.45	4808	128	80	43	105	186	3.0
	A4-M36		36						75	43	101	183	7.7*
	A4-1.08	1.1/2	39						76	43	101	183	3.4
	A4-M39		39						81	45	105	183	3.6
	A4-1.10	1.5/8	42						81	45	105	183	3.6
	A4-M42		42						86	48	107	187	3.9
	A4-1.12	1.3/4	42						86	48	107	188	3.9
PST-05	A5-1.10	1.5/8	42	96.1	942	9.73	6280	145	91	51	108	192	4.0
	A5-M42		42						87	48	113	198	11.4*
	A5-1.12	1.3/4	45						87	48	113	200	5.2
	A5-M45		45						92	51	117	205	5.4
	A5-1.14	1.7/8	48						93	51	117	206	5.4
	A5-M48		48						98	54	120	212	5.6
	A5-2.00	2	52						98	54	120	212	5.6
PST-06	A6-1.14	1.7/8	48	138.2	1354	13.99	9028	165	104	57	120	217	6.3
	A6-M48		48						105	57	120	217	5.9
	A6-2.00	2	52						99	54	120	209	14.8*
	A6-M52		52						99	54	120	210	7.1
	A6-M56		56						105	57	123	215	7.6
	A6-2.04	2.1/4	56						106	57	123	215	7.6
									113	62	126	223	7.8
									114	62	126	224	7.8

* Indicates weight of Load Cell +Adaptor Kit of particular size.

PST SERIES TOPSIDE BOLT TENSIONERS

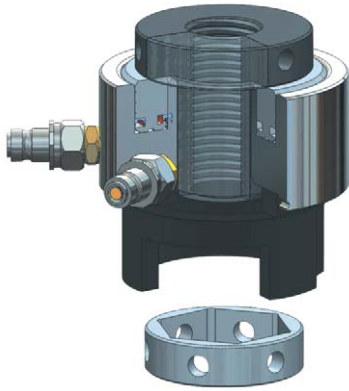

Model No.		Bolt Size		Max Load		Hyd Area		O.D.	Min Pitch	Relief C	Height A	Clearance B	Weight
Load Cell	Adaptor Kit	inch	mm	M Ton	kN	in ²	mm ²	mm	mm	mm	mm	mm	kg.
PST-07	A7-M56	2.1/4	56	168.5	1651	17.06	11006	180	112	62	129	222	18.1*
	A7-2.04		60						112	62	129	224	9.3
	A7-M60	2.1/2	60						117	62	132	229	9.4
	A7-2.08		64						125	68	135	236	9.7
	A7-M64		68						125	68	135	236	9.7
A7-M68	68	129	68	140	238	10.0							
PST-08	A8-2.08	2.1/2	64	201.8	1978	20.44	13188	198	129	70	137	242	23.4*
	A8-M64		68						129	70	138	242	12.1
	A8-M68	2.3/4	68						132	69	143	249	12.3
	A8-2.12		72						139	75	146	254	12.5
	A8-M72		72						141	75	146	256	12.5
PST-09	A9-2.12	2.3/4	72	230.3	2257	23.30	15045	215	139	75	146	261	29.3*
	A9-M72		76						141	75	146	261	15.6
	A9-M76	3	76						150	80	150	263	17.2
	A9-3.00		3						150	80	151	264	17.2
PST-10	A10-M80	3.1/4	80	310.9	3047	31.48	20312	244	160	87	158	275	40.3*
	A10-3.04		85						162	87	158	278	24.0
	A10-M85	3.1/2	85						164	87	160	275	24.5
	A10-3.08		90						174	93	164	280	22.6
	A10-M90		95						175	93	164	279	22.6
	A10-M95	3.3/4	95						179	93	170	281	22.8
	A10-3.12		100						191	105	170	281	22.9
	A10-M100	100	195						105	177	304	22.1	
A10-4.00	4	197	105	177	304	22.1							
PST-11	A11-3.12	3.3/4	100	384.5	3768	38.94	25120	280	192	106	172	299	52.7*
	A11-M100		110						196	106	179	306	31.4
	A11-4.00	4.1/4	110						198	106	179	299	31.4
	A11-4.04		120						209	111	186	312	36.4
	A11-M110		120						210	111	186	313	36.4
	A11-4.08	4.1/2	120						222	118	191	324	39.7
	A11-M120		125						226	118	198	330	41.4
	A11-4.12	4.3/4	125						229	121	202	342	42.3
A11-M125	125		233	121	202	348	43.3						
PST-12	A12-M125	5	125	485.1	4754	49.13	31694	325	236	124	204	354	89.6*
	A12-5.00		130						243	129	204	359	60.3
	A12-M130	5.1/4	130						243	126	207	361	63.1
	A12-5.04		140						254	135	210	367	63.1
	A12-5.08		140						266	141	217	380	70.4
	A12-M140	5.3/4	140						260	135	217	380	70.6
	A12-5.3/4		150						276	145	218	389	70.8
A12-M150	150	275	141	221	396	73.3							

* Weight of Load Cell + Adaptor Kit of particular size.

Please refer to catalog sheet - 'Basics of Tensioning' for Bolt Tensioners application and tool pressure calculation.

TSS SERIES SUB SEA BOLT TENSIONERS

TSS Series Bolt Tensioners are specially designed for sub sea applications. These Tensioners are suitable for higher pressure rating flanges also. Its ergonomic design makes it very easy to handle and use by divers under the harsh sea conditions. These tensioners are designed to provide a wide range of flexibility, covering stud sizes 3/4" to 3.1/2" (M-18 to M-85).

The tool consists of two basic parts - Tensioning Unit and Puller Nut as shown below:

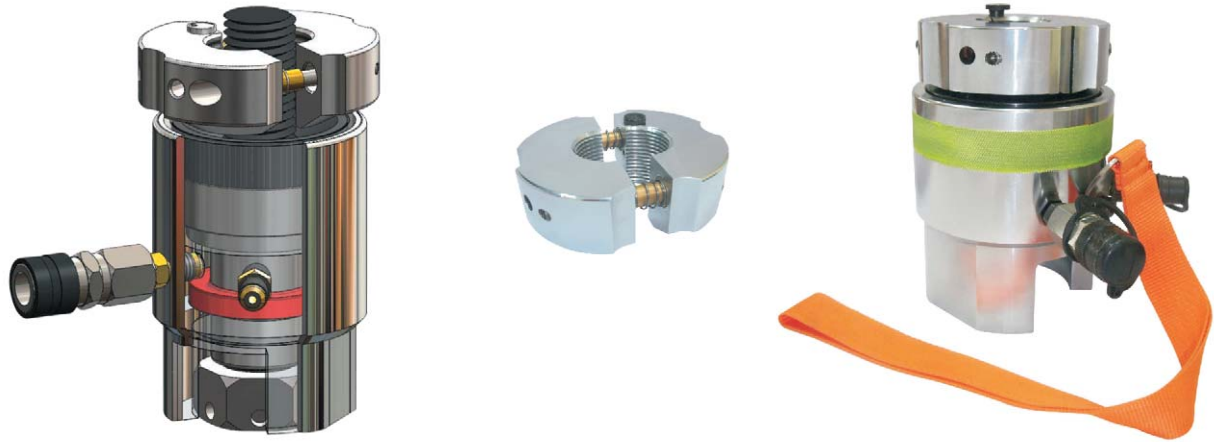

Features :

- **High Strength Stainless Steel Construction:** The Complete tool is made from high strength stainless steel for use in corrosive sea environment and to minimize maintenance. Optional alloy still construction also available.
- **Versatile Design:** Designed to provide a wide range of flexibility, covering stud sizes 3/4" to 3.1/2" (M-18 to M-85) using just 8 load cells.
- **Higher Load generation:** Generates higher load making it suitable for higher pressure rating flanges (API 170 - 10K).
- **Long Stroke And Stroke Indication:** All tensioners have a 25mm long stroke with piston marked with fluorescent rings for indication of stroke and over stroke limit.
- **Safe Design in event of Piston 'Over Stroke':** Designed to release high pressure hydraulic oil inwards in the event of over-stroke, thus saving the operator from any potential exposure.
- **Multi Tensioning:** The tensioning unit cell is provisioned with two connections that act as a manifold for multi tensioning applications.
- **Anti Roll, Composite Material Seals:** Fitted with Anti Roll, Composite Material seals for longer life and high reliability. The seals used have a low coefficient of friction so that the piston can be returned to a closed position with minimal effort. Sub Sea tensioners can be provided with machined PU (poly urethane) seals if requested by the customer.
- **Split Nut:** Optional Split Nut available for fast and easy fitment which ensures most efficient use of expensive diver time.
- **Safe Handling:** Provisioned with detachable hooks and strap for easy handling under water.
- **Non Slip Tool Surface:** Knurled and formed surface allows easy handling.
- **Fluorescent band:** Fluorescent band provided on load cell body for easy tool identification in poor visibility conditions.

TSS SERIES SUB SEA BOLT TENSIONERS

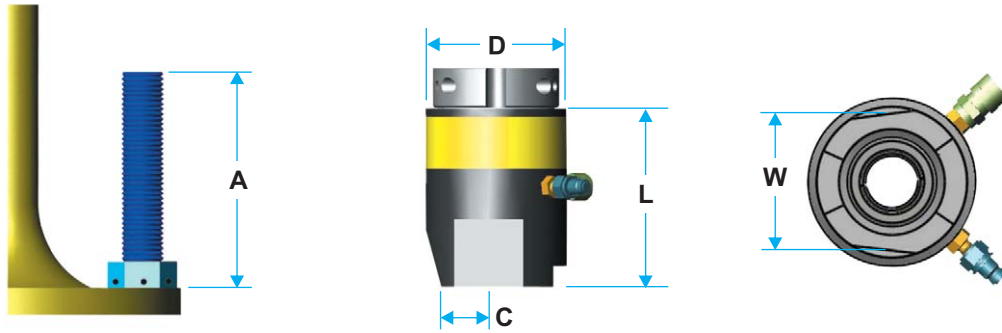

Technical Details:

Model No.		Bolt Size		Max Load		Hyd Area		D	C	W	L	A	Weight
Load Cell	Puller Nut.	inch	mm	Ton	kN	in ²	mm ²	mm	mm	mm	mm	mm	Kg.
TSS-03	PT03-0.12	3/4"		21.2	188	1.95	1256	65	30	46	100	122	2.0*
	PT03-M20		M20										0.3
	PT03-0.14	7/8"											0.3
TSS-04	PT04-M24			34.7	309	3.19	2061	86	30	64	123	153	4.0*
	PT04-1.00	1											0.7
	PT04-M27		M27										0.7
	PT04-1.02	1.1/8"											0.7
	PT04-M30		M30										0.7
TSS-05	PT05-1.04	1.1/4		54.2	482	4.98	3215	98	30	78	138	171	5.5*
	PT05-M33		M33									171	0.7
	PT05-1.06	1.3/8										174	0.7
	PT05-M36		M36									174	0.7
TSS-07	PT07-1.08	1.1/2		79.4	706	7.30	4710	117	30	93	147	186	7.4*
	PT07-M39		M39									186	0.8
	PT07-1.10	1.5/8										189	0.8
	PT07-M42		M42									189	0.8
TSS-11	PT11-1.12	1.3/4		119.1	1060	10.95	7065	138	60	113	152	197	13.5*
	PT11-M45		M45									197	3.5
	PT11-1.14	1.7/8										200	3.5
	PT11-M48		M48									203	3.5
	PT11-2.00	2"										206	3.8
	PT11-M52		M52									209	3.8
TSS-15	PT15-M56		M56	174.7	1554	16.06	10362	164	60	141	171	229	20.7*
	PT15-2.04	2.1/4"										229	5.0
	PT15-M60		M60									229	5.0
	PT15-2.08	2.1/2"										233	5.2
	PT15-M64		M64									233	5.2
TSS-20	PT20-2.12	2.3/4"		219.4	1952	20.17	13011	190	60	166	194	266	23.5*
	PT20-M72		M72									266	5.2
	PT20-M76		M76									269	5.2
	PT20-3.00	3"										269	5.2
TSS-27	PT27-M80		M80	268.7	2390	24.70	15935	214	60	191	208	288	31.5*
	PT27-3.04	3.1/4"										288	6.5
	PT27-M85		M85									293	6.5
	PT27-3.08	3.1/2"										293	6.5

* Weight of Load Cell + Puller Nut.

WIND MILL BOLT TENSIONERS

MSBT Series Bolt Tensioner :

These 1500 bar working pressure tensioners are specially developed from our Compact series to meet auto retract and ease of operation requirement of wind mill application.



Technical Details:

Model No.	Stud Dia		Outer Dia	Load	Stroke	OAL	A	B	C	Weight
	mm	inch								
MSBT-30	30	1.1/8	73	452	6	203	28	65	36.5	6.0
MSBT-33	33	1.1/4	78	516	6	229	32	73	39	8.0
MSBT-36	36	1.3/8	85	664	8	230	35	79	42.5	10
MSBT-39	39	1.1/2	94	862	8	252.5	37.5	81.5	48.5	12
MSBT-42	42	1.5/8	98	930	8	282	42	107	48.5	13
MSBT-45	45	1.3/4	108	1062	8	288	45	110	54	16
MSBT-48	48	1.7/8	114	1235	8	310	45	101	57	17

The main features of MSBT Series tensioners are as below :

- **Compact Design:** The tensioners are designed with smaller dia for ease of tool fitment.
- **Higher Working Pressure:** 1500 bar working pressure to generate higher load with smaller hydraulic area of tensioner.
- **Geared Nut Drive:** Geared Nut Driver to move the nut faster and with ease using standard 1/2" Square Drive Wrench.
- **Longer Stroke:** Tool is available with standard and long stroke as per application.
- **Alloy Steel Construction :** All parts are made from High Strength Alloy Steel better strength and compact design.
- **Customised Adaptor Kits :** CAT series tensioners are available with both standard and customised adaptor kit.
- **Optional Auto Spring Return:** Standard tensioners are available with optional auto spring retraction for fast and easy retraction of piston.

SPECIFIC APPLICATION BOLT TENSIONERS

Dedicated Tensioner :

Dedicated Tensioners are used for Specific Thread Size Application. In these tensioners the threaded piston acts as a puller too. These tensioners are specially designed for applications having space restrictions, around and the stud bolt.



These tensioners are designed and supplied to specific application requirement and have the below specific features:

- **Compact Design:** The dedicated tensioner has a very compact dia for required load and size with nominal requirement of operational height.
- **Customised Stroke:** Tool is available with standard 15mm and customised stroke as per application.
- **Alloy Steel Construction:** All parts are made from High Strength Alloy Steel for better strength and compact design.
- **Delivery:** In-house design and production facilities ensure faster customization and delivery.

Customized Tensioners :

These tensioners are designed for application where standard tensioner can not be accommodated due space and load requirements. Working pressure may be 1500 to 2500 as per application.

All parts of these tensioners are made of Special High Strength Alloy Steel for better design and safety requirement.



ELECTRIC BOLT TENSIONER PUMP PM-EH-1500



The PM-EH-1500 Electric motor with gear pump are designed to provide optimal service with bolt tensioner or hydraulic tools single-acting. Equipped with remote control with 5 m. cable for an easy use, 5 Ltr. tank, electromagnetic level and protective framework it is the ideal tool under all job conditions.

Model	PM-EH-1500	
Maximum pressure 1st stage	bar	150
	psi	2,145
Maximum pressure 2nd stage	bar	1,500
	psi	21,450
Hydraulic flow 1st stage	Lt./min	3
Hydraulic flow 2nd stage	Lt./min	0.7
Power rating and Voltage	kW / V	0.7 / 230 V - 50Hz / single-phase
Speed	rpm	1500
Sound level	dB(A)	80
Intensification factor		13 : 1
Electric pump weight	Kg.	42 (with 5 Lt. Reservoir, frame and remote control)

Other Models with higher maximum operating pressures, digital pressure gauges and larger hydraulic reservoir capacities are available as per customer requirements.

Technical Features :

- **Heavy Duty Steel Frame:** Unit is enclosed in heavy duty frame for protection during handling usage and transportation.
- **Calibrated Pressure Gauge:** Calibrated 100mm (4"), liquid filled, 2000 bar rating pressure gauge with dual reading of bar and psi.
- **Ergonomical layout:** Logical layout of equipments and controls ensure easy operation and maintenance.
- **High Flow Rate:** Provides high initial flow rate to ensure faster operation.
- **Remote Control:** Hand haled remote control for easy and safe operation.
- **High Quality Equipments:** Heavy duty cycle comforts for reliability and durability of the unit.

AIR OPERATED HYDRAULIC BOLT TENSIONER PUMP PU-AH-1500

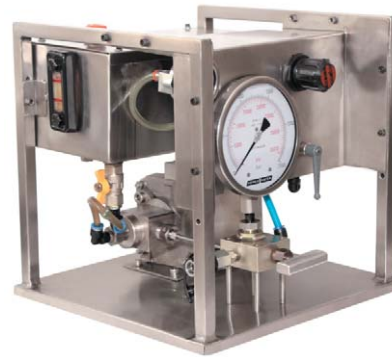

The PU-AH-1500 air operated pumps are designed and manufactured to meet the highest technical and safety requirements of high pressure equipment.

Model		PU-AH-1500
Pressure Ratio		1:350
Displacement Volume	Cm3	1.3
Operating Pressure, Max. (at 5.1 bar Pre Limited (PL) Air Pressure)	bar	1,800
Compressed air supply (air drive)		
System Operating Air Pressure, Max.	bar	5.1
Safety Valve Set Pressure	bar	5.5
Stainless Steel Tank Capacity		
Oil Tank capacity	litre	5

Other Models with higher maximum operating pressures, digital pressure gauges and larger hydraulic reservoir capacities are available as per customer requirements.

Technical Features :

- **Stainless Steel Frame:** The hydraulic unit is installed in a weather proof stainless steel protection frame.
- **Logical Control Panel:** Logical layout design engraved for easy operation.
- **Calibrated Pressure Gauge:** Calibrated 150mm (6"), liquid filled, SS Frame, 2500 bar rating pressure gauge with dual reading of bar & psi.
- **Complete Air System:** System includes FRL Unit, air pressure gauge and control knob for safe air control and supply.
- **Higher Operating Pressure:** Pump has max working pressure of 1500 bar to cover all bolt tensioning applications.
- **Light Weight:** Unit weighs only 22 Kg and measures 380mm x 80mm x 410mm.
- **Lower Input air Pressure:** Higher pressure ratio of 1 : 350 ensures less input air pressure for operation.
- **Quick Connect Outlet:** Pump comes fitted with quick connect outlet for easy connection of hydraulic hose.

HAND PUMP PU-HP-1500

Hand Pump

This hand pump is specially designed for bolt tensioner applications. The pump is compact and light in weight with longer handle needing very little effort to generate max working load. All pumps are supplied with suitable fittings and stainless steel 70mm dia pressure gauge.



Model No.	Description	Usable Oil Capacity (Liters)	Outlet Coupler	Dimensions			Net Weight Kg.
				Length mm	Width mm	Height mm	
PU-HP-1500	1500 bar Hand Pump c/w 200 bar gauge	3.0	HCS-150-F	615	200	190	12.0

HIGH PRESSURE ACCESSORIES

High Pressure Tensioner Hoses :

High Pressure Tensioner Hoses for various tensioning applications are available in different lengths and end-fittings:

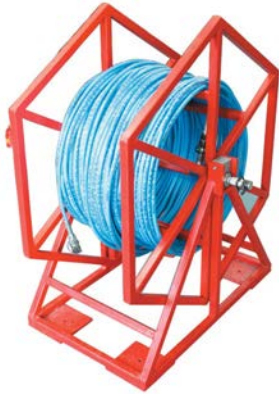

Hose Reel



Lead Hose



Connecting Hose

Features :

- 4- Ply construction.
- Available in 1.5m, 3m and 5m standard lengths. Other custom built lengths also available.
- Max. Working Pressure : 1800 Bar.
- Burst Pressure : 4500 Bar.
- Min. Bend Radius : 150mm
- All hoses fitted with quick connect Couplings at both ends.
- Working Temperature Range: -30 to 80 Deg C.
- Tensioner Hose Reel of upto 500m single hose for sub sea applications available with required end fittings.

Part No.	OAL Mtr.	QRC
PU-HG-0150	1.5	F X F
PU-HG-0300	3.0	F x F
PU-HG-0300-L	3.0	F x M
PU-HG-0500	5.0	F x F
PU-HG-0500-L	5.0	F x M

Manifolds, Fittings and Couplings :

Manifolds, Fittings and Couplings of various configurations are available for all tensioning applications:



Couplings



Fittings



Manifolds

Features :

- Manifold /Blocks for 1500 working pressure.
- T-Fittings for 1500 Bar working pressure.
- Male / Female Couplings for 1500 and 2500 bar working pressure.
- High Pressure Fittings and Adaptors.

Part No.	Description
HCS-150-F	Coupling, 150 Mpa
HCS-150-M	Nipple, 150 Mpa
HCS-250-F	Coupling, 250 Mpa
HCS-250-F	Nipple, 250 Mpa
HF-G4-G4	Fitting, G 1/4 CS
HF-G4-M16	Fitting G 1/4 x M16

BOLT TENSIONER APPLICATION

Important formula :

- (A) **Residual Bolt Load** = Bolt Stress x Bolt Tensile Stress Area
 = (Bolt Stretch x Modulus of Elasticity x Bolt Tensile stress area) ÷ Effective Length.
- (B) **Bolt Tensile Stress Area** = $(3.14 \times D \times D) \div 4$ (D is smallest Stress Dia of Bolt)
- (C) **% of Yield Strength** = (Bolt Stress Required / Yield Strength of bolt) x 100
- (D) **Hydraulic Pressure** = (Residual Bolt Load x Load Relaxation Factor) ÷ Hydraulic Area of Load Cell.
- (E) **Load Relaxation Factor** = $1.01 + (\text{Bolt Size (Dia.)} \div \text{Effective Length})$ or 1.1 which ever is greater.

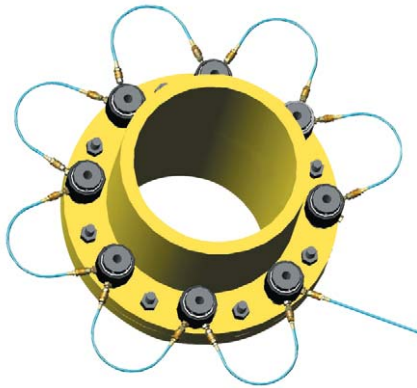

50% Tool Coverage

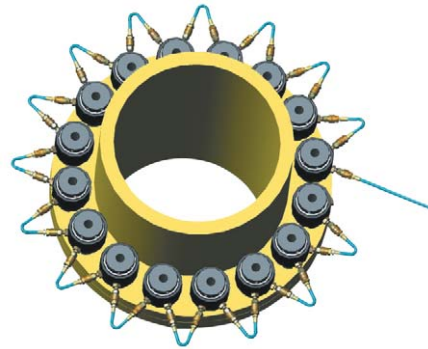

100% Tool Coverage

Basic Calculation and Working :

- a. Calculate Bolt Residual Load: Residual Load can be calculated from known stress or bolt stretch requirement.
- b. Calculate Load Relaxation factor using Bolt Dia and Effective Length. It can be calculated from below formula / Chart.

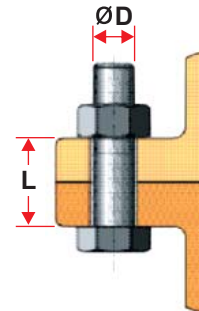
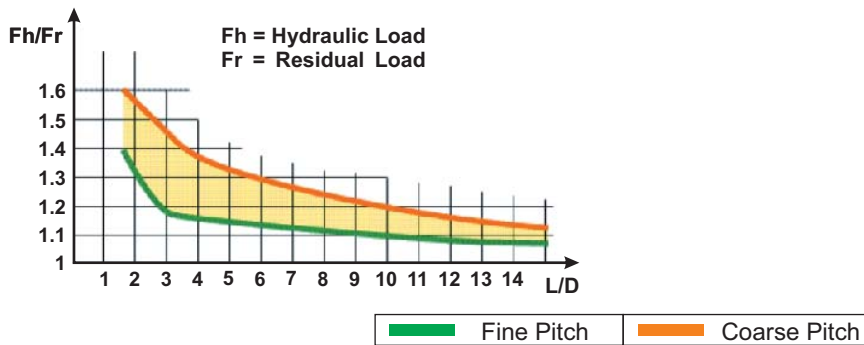

- c. Calculate application hydraulic load.
- d. Calculate hydraulic pressure for required hydraulic load.
- e. Select Tensioning Procedure. (25%, 50%, 100%...etc.)
- f. Calculate pass load as applicable. (Max applied load should never exceed 95% bolt yield strength).

Useful Conversions :

Area	: 1 millimeter ² (mm ²) = 0.00155 inch ² : 1 centimeter ² (cm ²) = 0.155 inch ²	1 inch ² = 645.16 mm ² 1 inch ² = 6.4516 cm ²
Load (Force)	: 1 Metric Ton (mt) = 1.10231 Short Ton (US) : 1 Kilo Niwton, kN = 224.8089 lb : 1 Metric Ton (mt) = 9.8066 kN	
Pressure	: 1 Megapascal (MPa) = 10 Bar : 1 Kg per cm ² (Kg/cm ²) = 0.98066 Bar	1 bar = 14.5037 psi 1 bar = 1.0197 Kg/cm ²

APPLICATION CHECKLIST

Dimensional Details

A) _____
 B) _____
 C) _____
 D) _____
 E) _____
 F) _____
 G1) _____
 G2) _____

H) _____
 I) _____
 J) _____
 K) _____
 L) _____
 M) _____
 N) _____
 O) _____

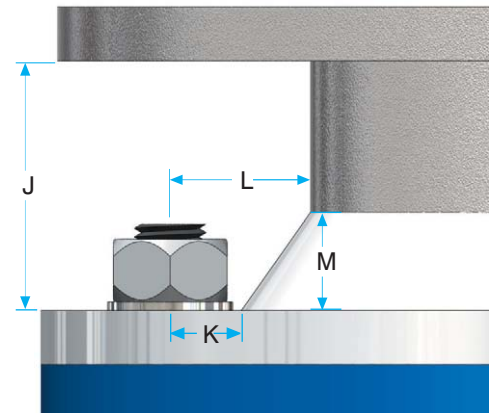
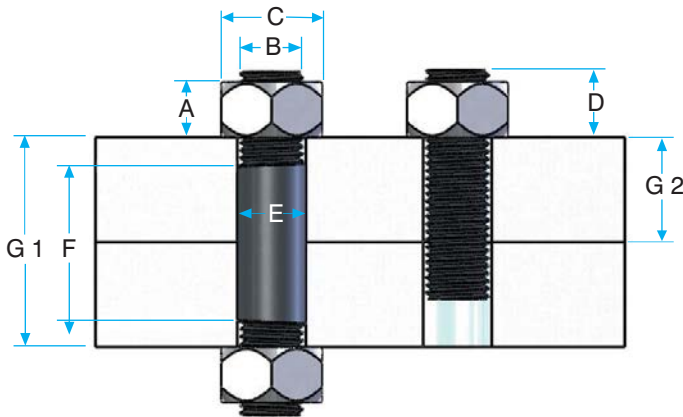
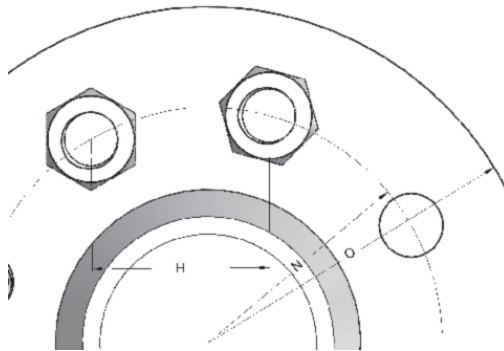

Thread Pitch / TPI. _____ Stud material. _____

Stud strength. _____ Desired retained stress in stud. _____

Depth if nut fits in a counterbore (or spot face depth). _____

Service temperature. _____ Desired stroke or amount of flange compression. _____

Will studs be loaded individually or several at a time? _____