

TORQUE MULTIPLIERS

Handtorque - Multipliers

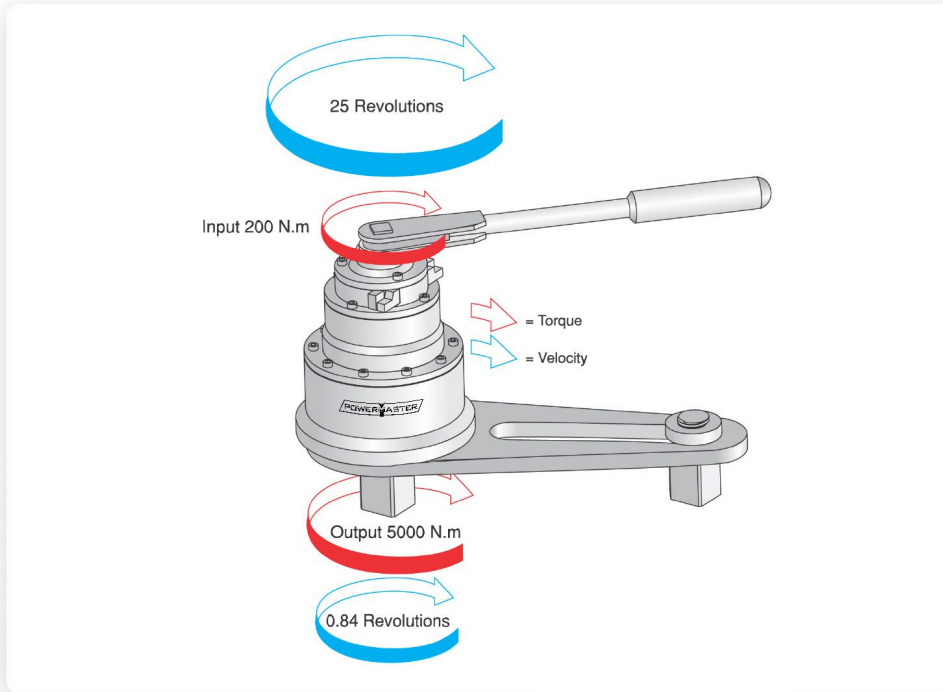

What is a Torque Multiplier?

It is a simple gear box, works on the principle of 'Epicyclic Gearing'. The given load at the input gets multiplied as per the multiplication factor and transmitted at the output, thereby with a minimum effort you achieve greater load.

How They Work ?

Handtorque multipliers incorporate an 'Epicyclic' or 'Planetary' gear train having one or more stages. Each stage of gearing increases the torque applied by a factor of 5, allowing to offer multipliers in ratios of 5:1, 25:1 and 125:1. In the planetary gear system, torque is applied to the input gear or 'Sun' gear. Three or four planet gears whose teeth are engaged with the sun gear and therefore rotate. The outside casing of the multiplier, or 'Annulus' is also engaged with the planet gear teeth, and would normally rotate in the opposite direction to the sun gear. A reaction arm prevents the annulus from rotating, and this causes the planet gears to orbit around the sun. The planet gears are held between input and output plate which also holds the output square drive. Therefore as the planetary gears orbit around the sun gear, output plate turns and so the square drive turns. Without the reaction arm to keep the annulus stationary, the output square will not apply torque.

Why use a Torque Multiplier?

Safety - Use of long levers can be dangerous. Torque multipliers mean a reduction in the lever length or operator effort by a factor of 5, 25 or 125. **Space Limitation** - The use of a long lever may be impossible due to restricted space.

Accuracy - Torque will be applied most accurately when it is applied smoothly and slowly. Torque multipliers enable this by removing much of the physical effort from the tightening task.

Advantages Of Torque Multipliers :

- The ratio stated is the true torque multiplication factor.
- No correction charts are needed to determine torque output.
- Strong, safe Anti Wind-Up Ratchet available on most models for safe and comfortable operation.
- A wide range of alternative reaction arms are available as per customer requirement, making the Torque Multiplier adaptable to many applications.

TORQUE MULTIPLIERS

Anti Wind-Up Ratchet (AWUR) :

With any high ratio gearbox (25:1 or more) a certain amount of wind-up (spring) has to be taken up before any useful tightening work is applied to the nut.

Each time the input device is released, the wind-up will rotate it back against the direction of operation.

The Anti Wind-Up Ratchet retains all of the wind-up forces as they are created, with the following benefits :

1. The torque input device can not fly backwards against the direction of operation if it is suddenly released.
2. Without an Anti Wind-Up Ratchet, it will often be necessary to continue to make 360 sweeps with the torque input device otherwise the multiplier will 'unwind'. However, obstructions will often make this impossible.
3. With an Anti Wind-Up Ratchet fitted, the multiplier becomes locked onto The nut because the reaction plate is held hard against the reaction point. This means that even used upside down, the multiplier will support it's own weight.



Standard Series Anti Wind-Up Ratchet.

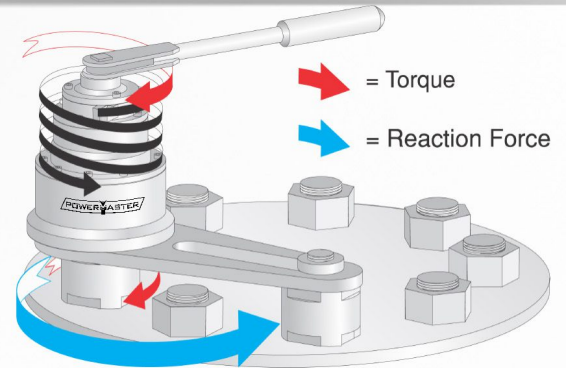

Multiplier behaves like a very stiff 'Spring'

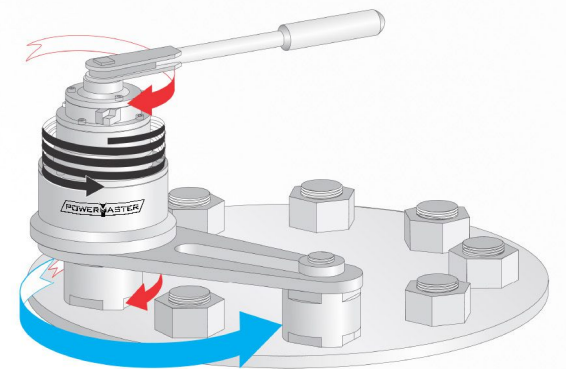

Multiplier will achieve maximum torque only after the 'Spring' has been taken up.

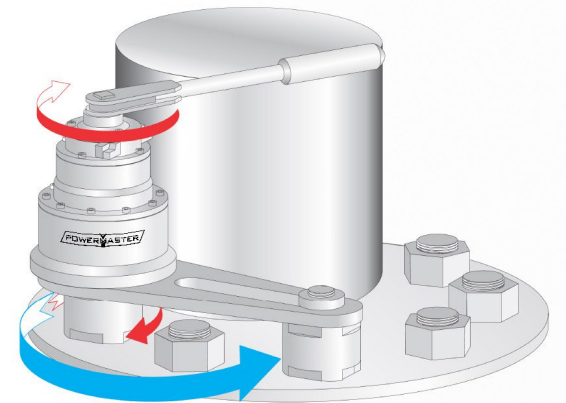

In this application, if it takes more than 180° to take up the wind-up at the required torque, this tightening operation will be impossible without an 'Anti Wind-Up Ratchet'.

Safety Note : Additional support is recommended as failure in the bolt, socket or multiplier will release the wind-up forces and cause the multiplier to drop.

TORQUE MULTIPLIERS

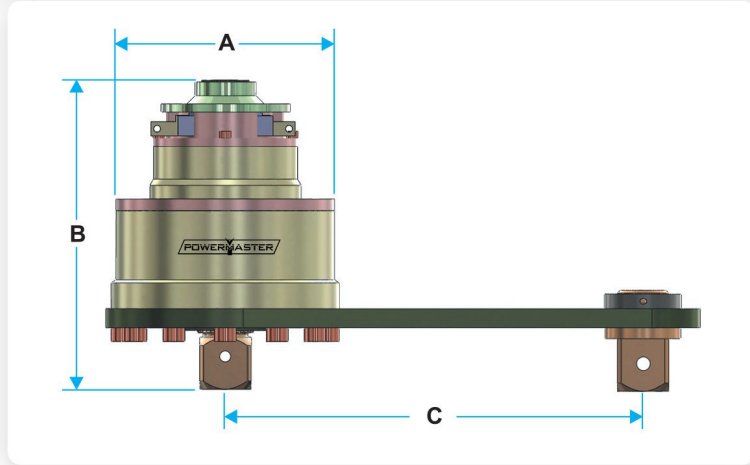

Features :

- Accuracy better than $\pm 4\%$.
- Precision tightening and loosening of all heavy duty fasteners.
- Low energy input with high torque transfer.
- Higher capacity multipliers are furnished with strong ratchets (Anti-wind up mechanism) allowing jobs to be performed easily, efficiently, and safely.
- Precision Manufacturing ensures long life and premier quality.
- A groove on output Square breaks if over loaded in excess of 20% of its capacity.
- Highest possible load factor is guaranteed due to design and use of forged components.

Standard Series, to 47500 N.m

Model No.	Capacity		Ratio	Input Square	Output Square	A	B	C	C	Weight*	
	N.m	lbf.ft		inch	inch	\emptyset	mm	mm	min	max	kg
PTM-6	3400	2500	5	3/4	1.1/2	116	158	105	260	9.20	20.24
PTM-6/25	3400	2500	25	1/2	1.1/2	116	211	105	260	12.00	26.40
PTM-7	6000	4500	5	3/4	1.1/2	142	170.5	115	310	18.00	39.60
PTM-7/25 Fitted with AWUR	6000	4500	25	1/2	1.1/2	142	230	115	310	22.00	48.40
PTM-9/25 Fitted with AWUR	9500	7000	25	3/4	1.1/2	196	243	150	350	33.00	72.60
PTM-9/125 Fitted with AWUR	9500	7000	125	1/2	1.1/2	196	325	150	350	35.50	78.10
PTM-11/25 Fitted with AWUR	17000	12500	25	3/4	2.1/2	220	355	164	480	52.00	114.40
PTM-11/125 Fitted with AWUR	17000	12500	125	1/2	2.1/2	220	404	164	480	57.00	125.40
PTM-13/125 Fitted with AWUR	47500	35000	125	3/4	2.1/2	315	550	164	480	80.00	176.00

* Including reaction plate.