

1 3/4" - 4"  
O.D.

**LONG REACH CSB SERIES**

- Features :*
- '5 Roll' design is used primarily for rolling thin walled tubes used in sugar mill juice heaters, pans.
  - '5 Rolls' give you a more concentric, uniform expansion vs. a '3 roll' expander in thin tubes and reduces tube 'spring back' effect.
  - Use - For bottom plate tube expansion in pans, juice heaters in sugar mills.

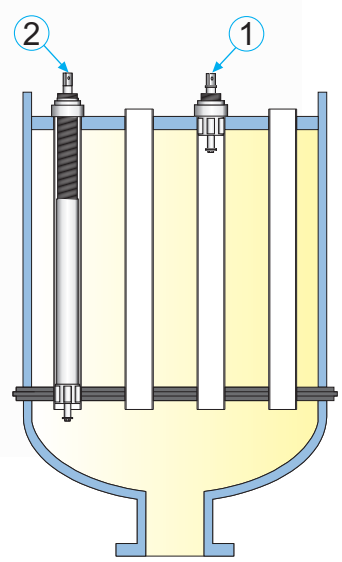
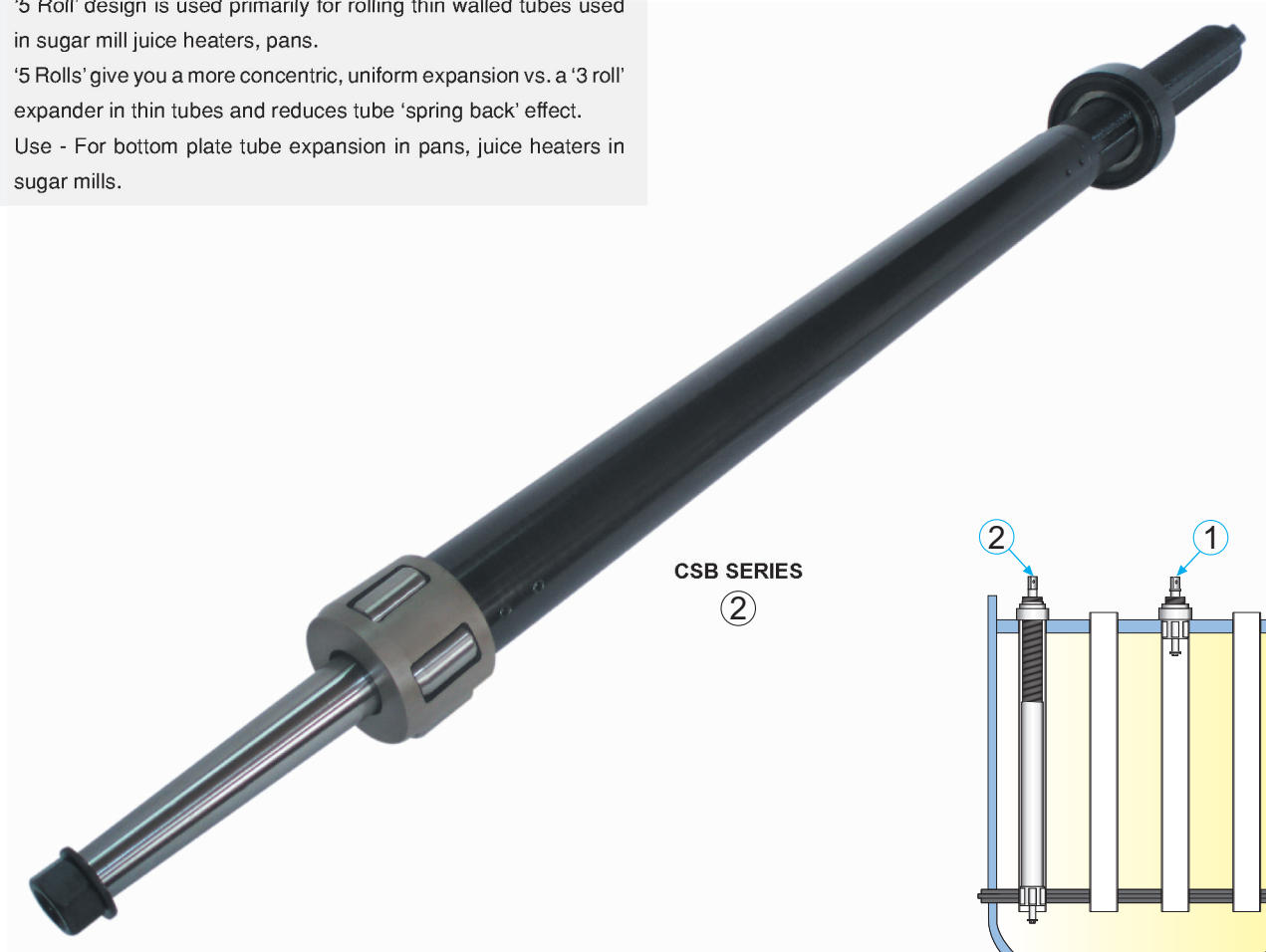

Tube O.D.	Tube Thickness		Minimum I.D. Tool Enters		Maximum Expansion Of Tool		Tube Sheet Thickness 'T'		Depth in Mtrs.		Mandrel Sq. Size	Oal	Weight in Kgs.	Tube Expander Model No.	Spare Mandrel Model No.	Spare Rollers Set Model No.
	inch	bwg	inch	mm	inch	mm	inch	mm	inch	min						
<b>CSB-5 (3 Rollers)</b>																
1.3/4	15 & 16	.072 & .065	39.8	1.566	45.3	1.783	32.0	1.259	1.7	2.0	3/4	2.258	10.0	CSB-5STD	CSBM-5STD	CSBR-5
1.3/4	15 & 16	.072 & .065	39.8	1.566	45.3	1.783	32.0	1.259	2.0	2.3	3/4	2.558	11.2	CSB-5A	CSBM-5A	CSBR-5
1.3/4	15 & 16	.072 & .065	39.8	1.566	45.3	1.783	32.0	1.259	2.3	2.3	3/4	2.858	12.4	CSB-5B	CSBM-5B	CSBR-5
1.3/4	15 & 16	.072 & .065	39.8	1.566	45.3	1.783	32.0	1.259	2.6	2.9	3/4	3.158	13.7	CSB-5C	CSBM-5C	CSBR-5
1.3/4	15 & 16	.072 & .065	39.8	1.566	45.3	1.783	32.0	1.259	2.9	3.2	3/4	3.458	14.9	CSB-5D	CSBM-5D	CSBR-5
1.3/4	15 & 16	.072 & .065	39.8	1.566	45.3	1.783	32.0	1.259	3.2	3.5	3/4	3.758	16.2	CSB-5E	CSBM-5E	CSBR-5
<b>CSB-9 (5 Rollers)</b>																
2	14 - 16	.083 - .065	46.2	1.818	50.8	2.000	32.0	1.259	1.7	2.0	3/4	2.241	16.2	CSB-9STD	CSBM-9STD	CSBR-9
2	14 - 16	.083 - .065	46.2	1.818	50.8	2.000	32.0	1.259	2.0	2.3	3/4	2.541	18.3	CSB-9A	CSBM-9A	CSBR-9
2	14 - 16	.083 - .065	46.2	1.818	50.8	2.000	32.0	1.259	2.3	2.3	3/4	2.841	20.4	CSB-9B	CSBM-9B	CSBR-9
2	14 - 16	.083 - .065	46.2	1.818	50.8	2.000	32.0	1.259	2.6	2.9	3/4	3.141	22.5	CSB-9C	CSBM-9C	CSBR-9
2	14 - 16	.083 - .065	46.2	1.818	50.8	2.000	32.0	1.259	2.9	3.2	3/4	3.441	24.6	CSB-9D	CSBM-9D	CSBR-9
2	14 - 16	.083 - .065	46.2	1.818	50.8	2.000	32.0	1.259	3.2	3.5	3/4	3.741	26.7	CSB-9E	CSBM-9E	CSBR-9
<b>CSB-24 (5 Rollers)</b>																
4	12 - 18	.109 - .049	90.5	3.563	102.4	4.031	32.0	1.259	0.7	1.0	1	1.416	23.7	CSB-24STD	CSBM-24STD	CSBR-24
4	12 - 18	.109 - .049	90.5	3.563	102.4	4.031	32.0	1.259	1.0	1.3	1	1.716	29.4	CSB-24A	CSBM-24A	CSBR-24
4	12 - 18	.109 - .049	90.5	3.563	102.4	4.031	32.0	1.259	1.3	1.6	1	2.016	35.5	CSB-24B	CSBM-24B	CSBR-24
4	12 - 18	.109 - .049	90.5	3.563	102.4	4.031	32.0	1.259	1.6	1.9	1	2.316	40.8	CSB-24C	CSBM-24C	CSBR-24
4	12 - 18	.109 - .049	90.5	3.563	102.4	4.031	32.0	1.259	1.9	2.2	1	2.616	46.5	CSB-24D	CSBM-24D	CSBR-24
4	12 - 18	.109 - .049	90.5	3.563	102.4	4.031	32.0	1.259	2.2	2.5	1	2.916	52.5	CSB-24E	CSBM-24E	CSBR-24

**Note :** Other sizes, special lengths are available on request.